

CERTIFICATION



HACCP International



ISO9001

# ICE MATE



## SRM-45A

### ICE MAKER

ICEMATE is committed to bringing high-efficiency / energy-saving, and high quality ice-making product to people who have dreams and desire to create their own business with the best scientific technology and manufacturing technology.

#### DICE

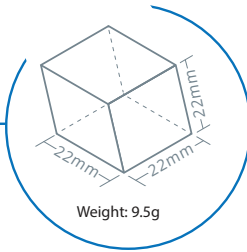

#### KEY FEATURES

##### SAFETY AND HYGIENE ASSURED ICE MACHINE



NSF Certified Material for Bin and Scoop



Detachable Parts for Easy Cleaning



Air Filter Prevent Dust from Entering



Stainless Steel

##### PERFECT FIT & SPACE SAVING



Compact Design for Under-Counter Installations



Front Intake and Exhaust System

##### EASY MAINTENANCE



IoT



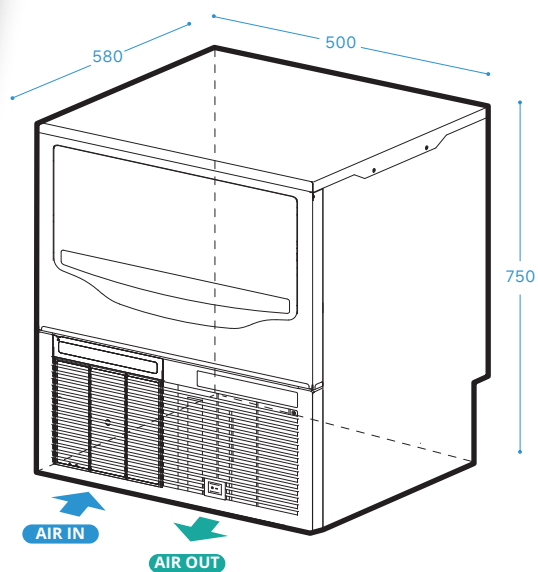

TOP SIDE

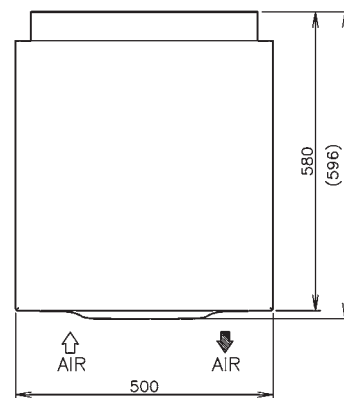

FRONT SIDE

RIGHT SIDE

BACK SIDE

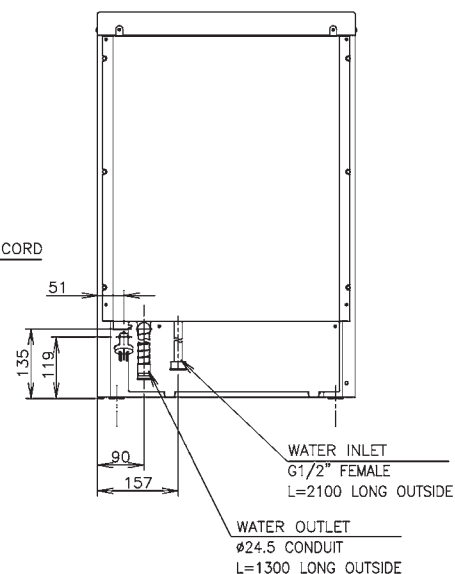
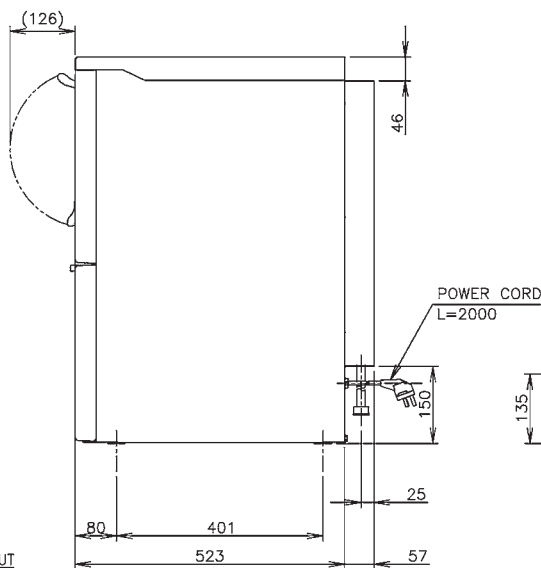
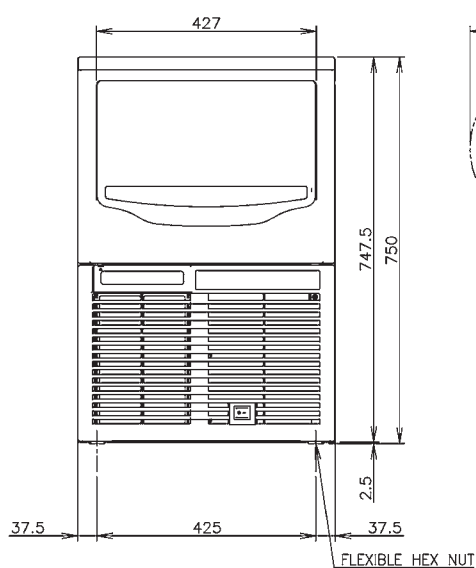

SPECIFICATIONS

Ice Dimensions (W x D x H)	22 x 22 x 22 mm
Outside Dimensions (W x D x H)	500 x 580 x 750 mm
Package Dimensions (W x D x H)	Carton: 625 x 716 x 875 mm
Weight (Net / Gross)	36 kg / 40 kg
Amperage / Starting Amperage	2.05A / 15.5A
Electrical Consumption	287 W
Refrigerant Charge	R134a / 160g
Ice Storage Capacity	Maximum 14kg
Ice Production per 24H	(AT10°C / WT10°C) Approx. 46 kg (AT21°C / WT15°C) Approx. 41 kg (AT32°C / WT21°C) Approx. 35 kg

Water Consumption per 24H	(AT32°C/WT21°C) 0.06m <sup>3</sup> (1.8L / kg Ice)
Ice Production Freeze Cycle Time	(AT21°C/WT15°C) 18 min
Ice Production per Cycle	(AT21°C/WT15°C) Approx. 0.5kg / 55 pcs

OPERATING CONDITIONS

Voltage Range	198 - 254 V
Ambient Temperature	5 - 38°C
Water Supply	5 - 32°C
Water Supply Pressure	0.07 - 0.55 Mpa (0.7 - 5.5 bar)
Supply Voltage	1/220 - 240V / 50Hz

